

# HEAT AIR Ford Transit Custom Space Heater Bracket Installation - AK1820B

Please refer to Heat Air operating and installation instructions for a comprehensive guide to heater operation and installation.

Veuillez vous reporter aux instructions d'utilisation et d'installation de Heat Air pour un guide complet sur le fonctionnement et l'installation du réchauffeur.

Consulte las instrucciones de uso y de instalación de Heat Air para una guía completa sobre el funcionamiento y la instalación del conductor.

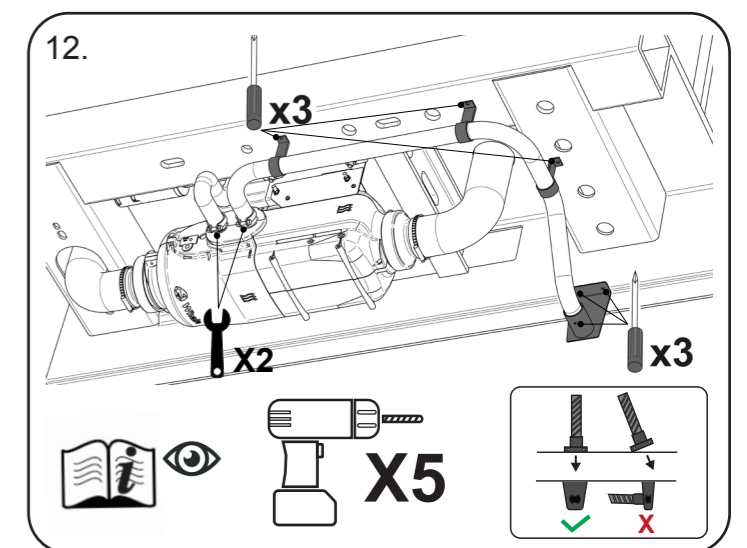
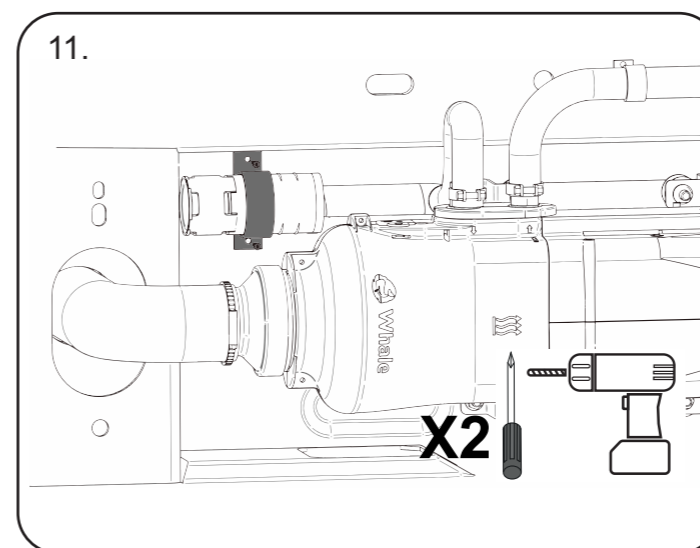
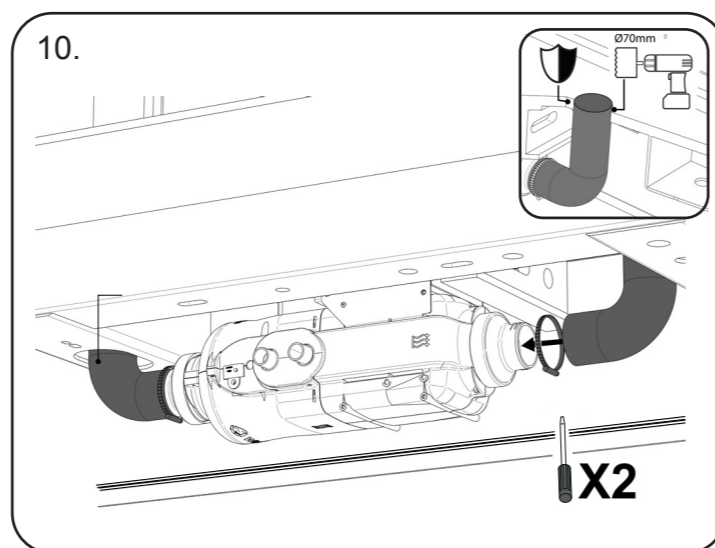
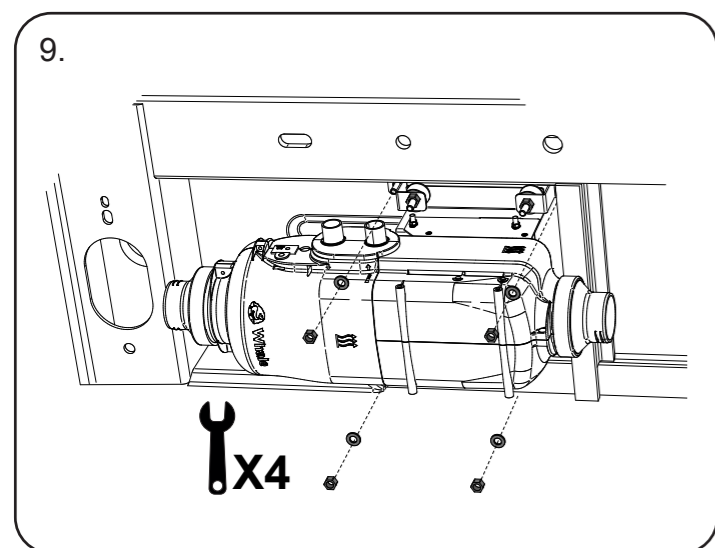
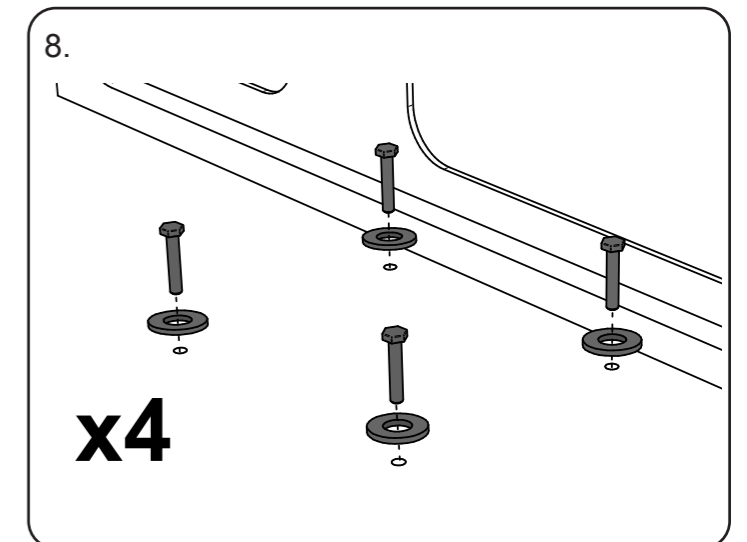
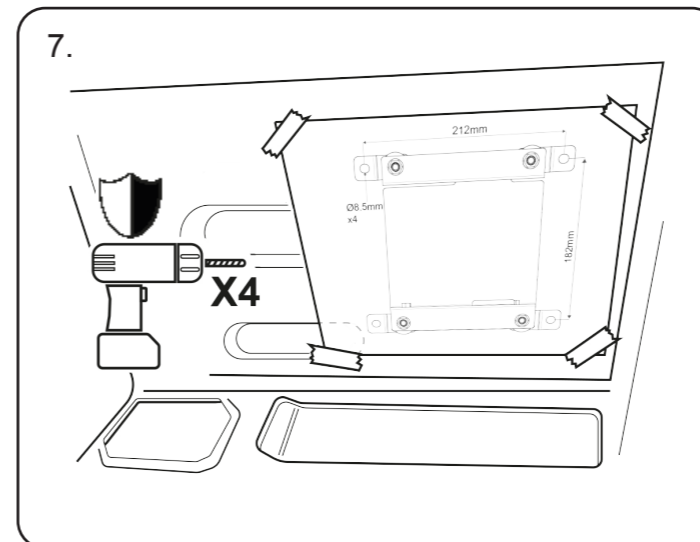
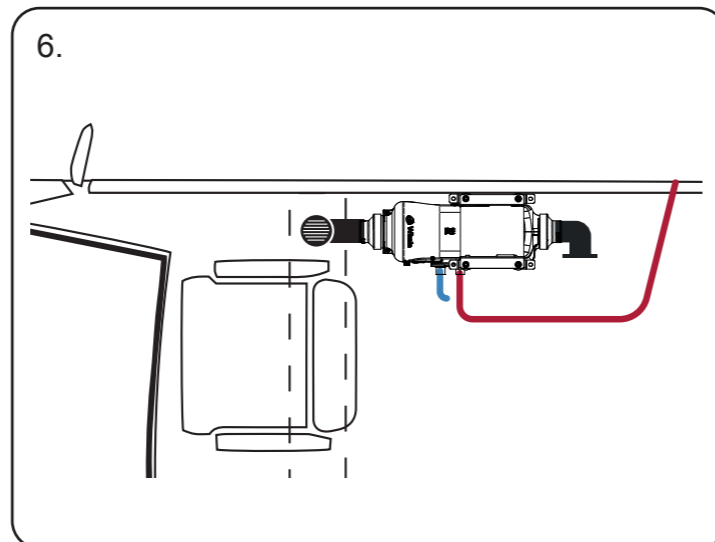
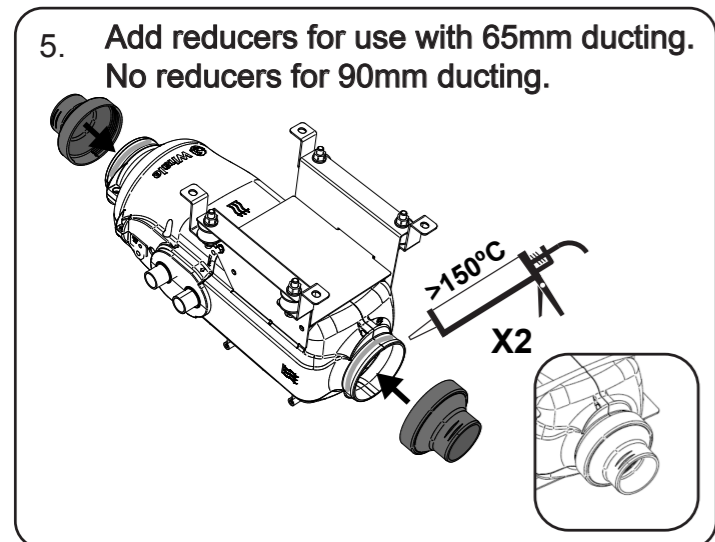
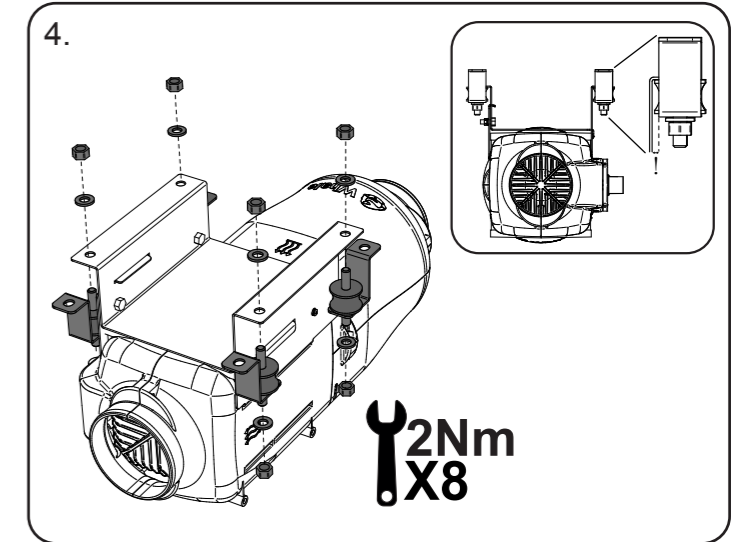
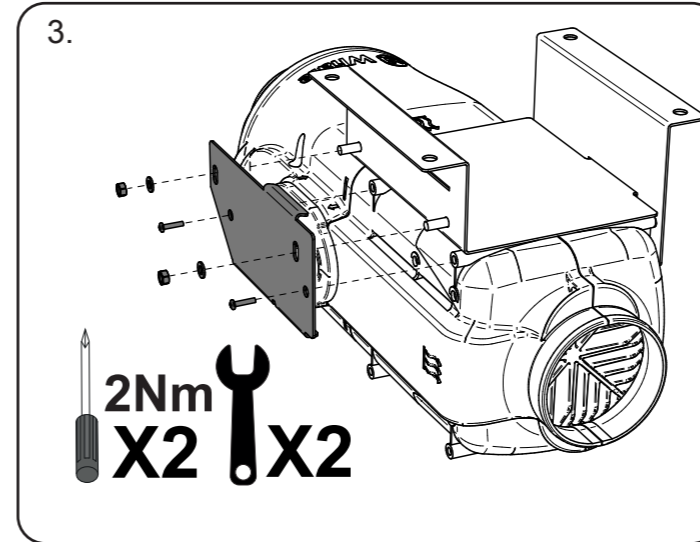
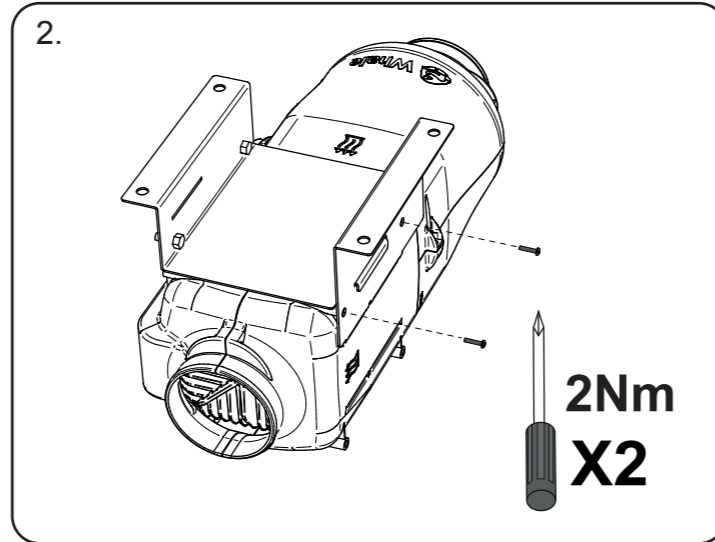
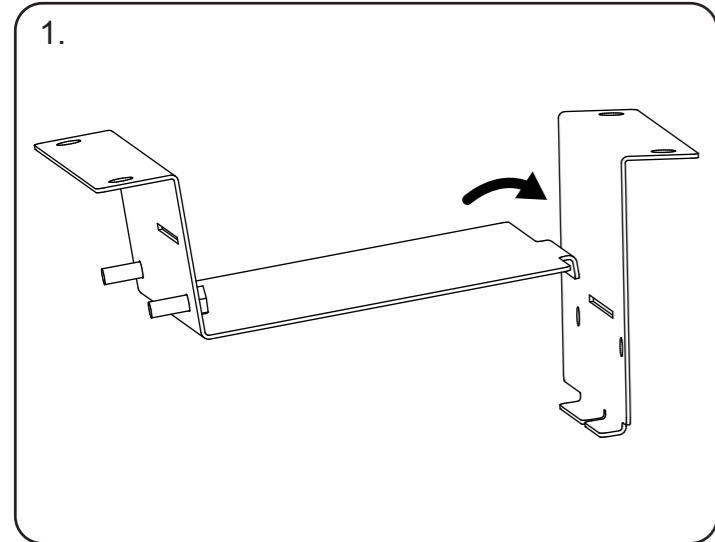

**Ford Transit Custom Space  
Heater Bracket Drill Template**

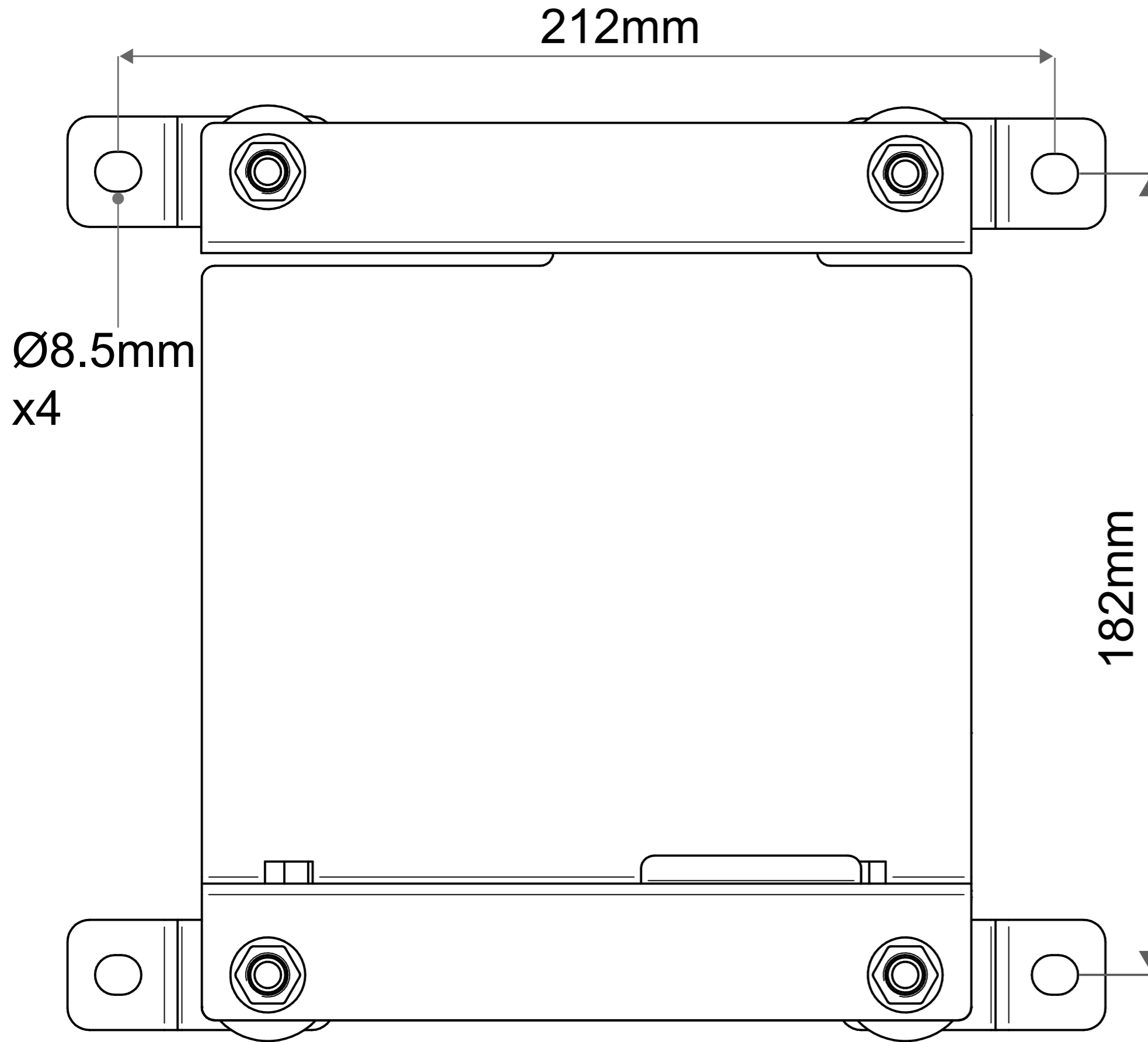

EU Tech Support  
Munster Simms Engineering Ltd  
2 Enterprise Road, Bangor,  
N. Ireland BT19 7TA  
Tel: +44 (0)345 9090 911  
Tel: +44 (0)28 9127 0531  
Email: info@Whalepump.com

whalepumps.com  
whalevanlife.com



USA & Canada Tech Support  
Munster Simms Engineering Ltd  
2 Enterprise Road, Bangor,  
N. Ireland BT19 7TA  
Tel: +1 616 897 2301  
Email: USASales@Whalepump.com

whalepumps.com  
whalevanlife.com

